

OPTO S2+



ITEM DESCRIPTION

OPTO S2+ is a new solution for uniform illumination of medium to bigger size channel letters with depth ranging from 80 to 150 mm. Light in the applications distributed more evenly, due to the new optics, we have used in this series design. Because of that, LED modules can have longer wires and be installed with a 300 m step. 24V gives the ability to increase the number of LED modules in the chain, without drop of the effectiveness and power. To make the installation work easy and fast, these modules come with the adhesive containing a finger lift edge liner for convenient removal of the protective layer. OPTO S2+ modules have 10 years (24/7)* warranty with L80 for 50 000 hours.

APPLICATION

- Medium to bigger size channel letters
- Recommended depth 80 – 150 mm

FEATURES & BENEFITS

- Efficiency up to 160 lm/W
- 300 mm distance between centers of modules
- IP67 protection class
- L80 50, 000 h lifetime
- 10-year 24/7 warranty*
- Easy tear finger-lift tape for faster installation

10 YEARS LIMITED WARRANTY

80 - 150

160°

6500 K

160 lm

1.0 W

IP 67

L80 50 000 h

GENERAL SPECIFICATIONS

SUPPLY VOLTAGE	24 VDC
POWER	1.0 W
RECOMMENDED DEPTH	from 80 to 150 mm
CC DISTANCE	300 mm
BINNING	3 SDCM
OPERATING TEMPERATURE	-20 °C ~ +50 °C
STORAGE TEMPERATURE	-30°C ~ +60 °C
STORAGE CONDITIONS	Relative humidity <60%
CERTIFICATION	CE, RoHS and UKCA compliant
IP CLASS	IP67
LIFETIME	L80 50,000 h
WARRANTY	10 years (24/7)*

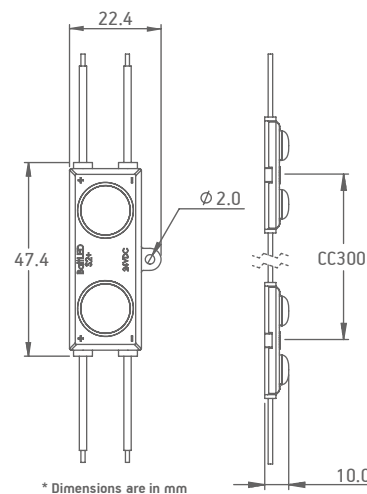

*Limited ten (10) years warranty is valid for the products only if BaltLED LED drivers(power suppliers) are used in the complete system starting with the SKU of BPSP-... and BPSE-... In other case, a standard 5 years warranty is given. Warranty is applied only and if storage, mounting and maintenance conditions, stated in the installation guide, are followed.

LIGHT DISTRIBUTION GRAPH

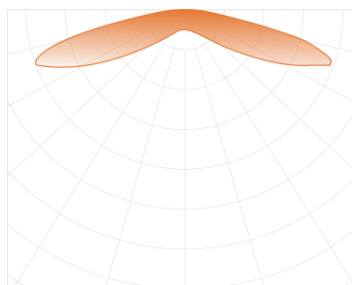

Beam angle: 160°

ORDERING INFORMATION

SKU	POWER, W	LUMEN OUTPUT, LM	COLOUR TEMP.
BMP-S2P.1-730E1-24V	1.0	148	3000 K
BMP-S2P.1-740E1-24V	1.0	160	4000 K
BMP-S2P.1-765E1-24V	1.0	160	6500 K

PACKAGING INFORMATION

CHAIN	BAG	BOX
45 pcs (0.7 kg)	90 pcs (1.3 kg)	720 pcs (11.0 kg)

© 2024, All rights reserved BaltLED, UAB. Specifications are subject to change without notice.