

EDGELIT SLIM LED RIGID BAR

installation guide

READ THE INSTRUCTIONS CAREFULLY BEFORE MOUNTING

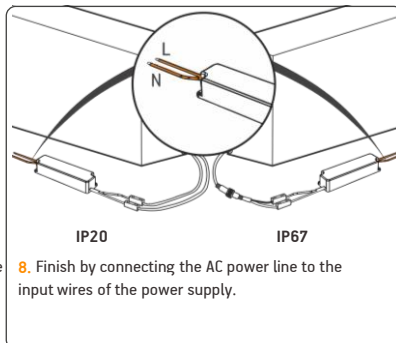
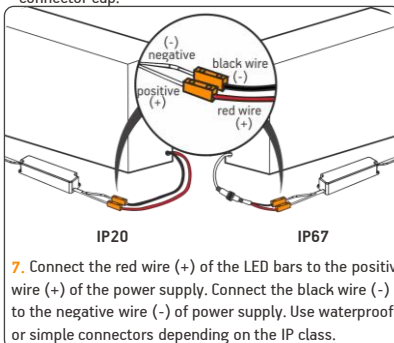
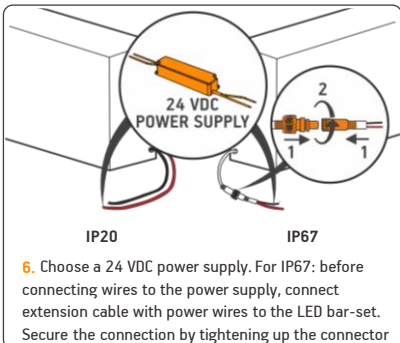
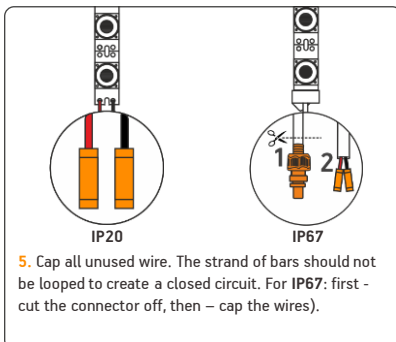
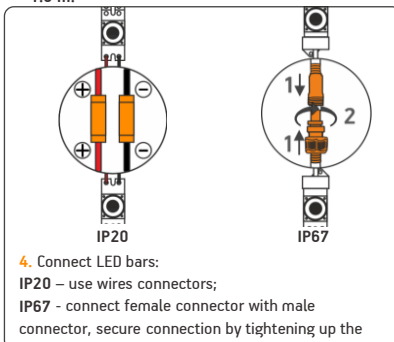
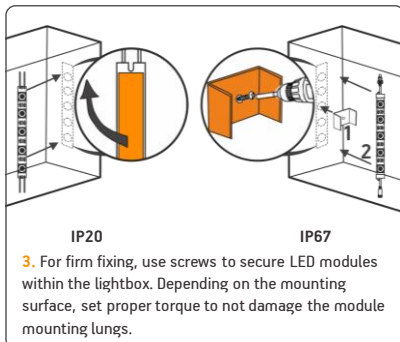
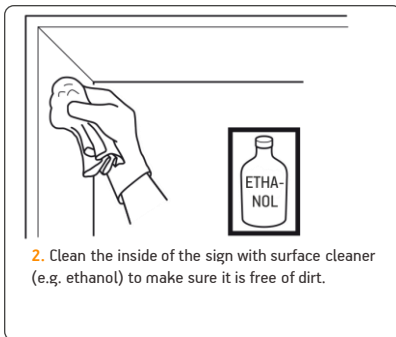
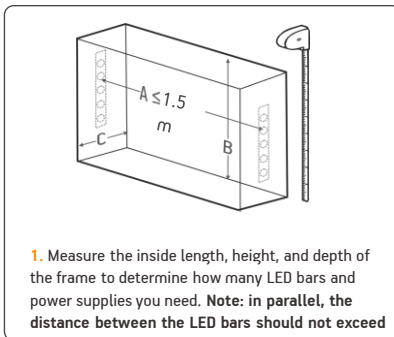
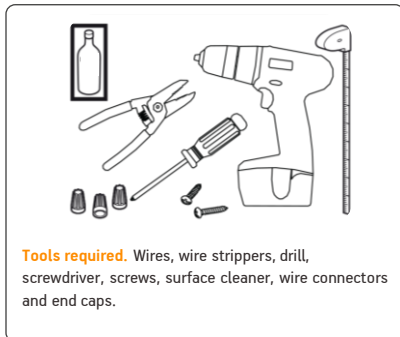

CONNECTION SCHEME

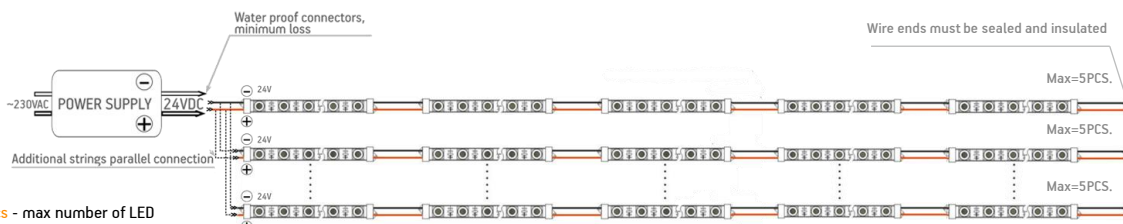

! 5 pcs - max number of LED bars in one chain when the power supplied from single end.
 ! String end voltage can't be less than 20V, do not exceed specified module string length

POWER SUPPLY LOAD RECOMMENDATIONS

SKU	NOMINAL POWER	MAX POWER OF CONNECTED BARS
BPSP-60-24V.1	60 W	55 W
BPSP-100-24V.1	100 W	90 W
BPSP-150-24V.1	150 W	135 W

! Power loss less than 5%.
 ! Recommendations for optimal use of power supply.



EDGELIT SLIM LED RIGID BAR

installation guide

READ THE INSTRUCTIONS CAREFULLY BEFORE MOUNTING

SAFETY PRECAUTIONS

- Installation of LED bars must be carried out by a qualified technician in accordance with relevant electrical equipment handling standards.
- Before installing, make sure that the fixing area can bear the total weight of the LED bars.
- LED bars and power supplies have absolute maximum ratings. Comply with the specifications to avoid failure, damage, and injury.
- Do not modify LED bars. This may lead to damage, injury, and will void the warranty.
- Do not connect the LED bars to a power supply that is turned on! Injury and LED bar failure may occur. If a power supply is turned on with no load (for example because of a bad connection), turn the power supply off and allow 5 minutes for it to fully discharge before continuing work on the installation.
- Avoid placing any high temperature objects around the LED bars. Also avoid putting cloth or paper on the LED bars. It may lead to combustion, burnout, overheating, failure, and deformation.
- Before performing maintenance, turn off the power and allow the LED bars to cool down. Otherwise, there is a danger of burns or electric shock.
- Do not wipe or spray LED bars with volatile materials such as thinner or benzene as it may lead to damage or spontaneous combustion.
- If there are any signs of smoke or there is a smell of burnt plastic, turn off power to the installation immediately and investigate the power supply and wiring carefully.
- Ensure that power supply and other system components are properly earthed if using Class 0 or Class I power supplies.

INSTALLATION RECOMMENDATIONS

- The adhesive tape is for temporary mounting only! Additional adhesives or fasteners must be used for permanent installation.
- Be sure to install LED bars in maintainable places.
- Avoid using excessive force during installation in order to minimize the risk of damage to LED bars or cabling.
- Be careful not to go beyond the recommended maximum quantities of LED bars for a given power supply. Overload may cause blinking, uneven illumination, or failure.
- These LED bars are designed to work with constant-voltage power supplies. Use only recommended power supplies. Do not connect to constant-current power supplies, as doing so will cause immediate failure of LED bars.
- Please install LED bars using appropriate cables. There is a possibility of cables disconnecting or breaking due to shrinkage caused by temperature changes.
- Make sure to provide sufficient ventilation and rainwater drainage for the installation containing the LED bars to prevent shortening their lifetime due to excess heat, long-term exposure to water or ice damage. Operating temperature should be within -30-50 °C.
- When fixing the cabling of the installation, avoid using metal cable ties or brackets – they may damage the cable insulation and cause short-circuits.
- In order to prevent LED breakdown caused by static discharge, make sure not to touch the wiring of the LED bars with bare hands.
- Make sure to check the LED bar connections for the correct polarity. Reversed connections may lead to failure.
- Do not pull on the wiring while removing the LED bars – risk of damage.
- Do not install LED bars under direct sunlight or falling water – premature failure may occur.

STORAGE AND GENERAL REMARKS

- Make sure to store LED bars in a dry place, avoid elevated temperatures, high pressures, vibrations, corrosive or combustible materials, direct sunlight.
- EdgeLit LED bars cannot be used in combination with other types of LED bars. This may cause color and brightness mismatches and lead to premature failure.
- Please ensure that the materials and components used in the installation do not contain or emit sulphuric compounds. Sulphuric compounds attack the LED bar components and may lead to changes in color and premature failure.
- Make sure to keep records of the lot numbers and installation dates of the LED bars.