

5 YEARS WARRANTY

IP 65

CE

UK CA

RoHS Compliant

RoHS Compliant

# MINI HE installation guide

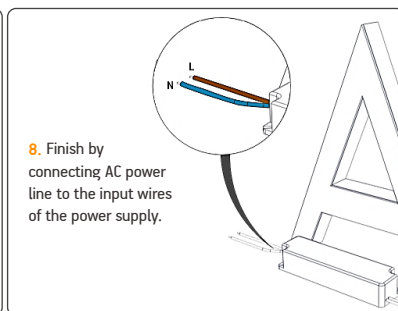
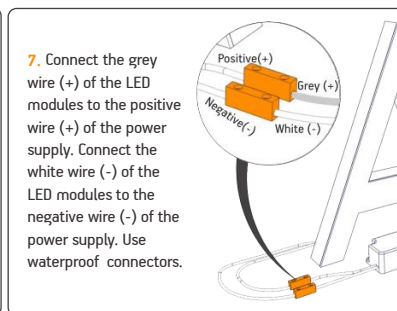
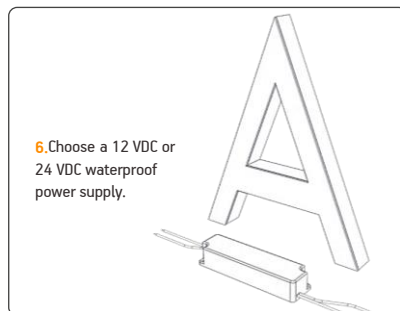
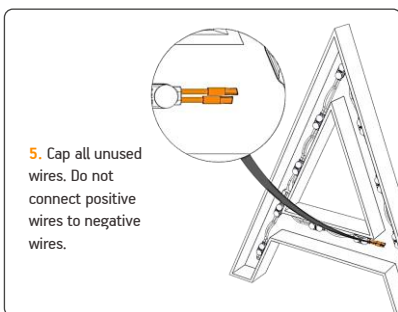
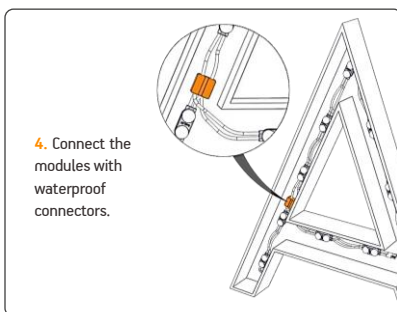
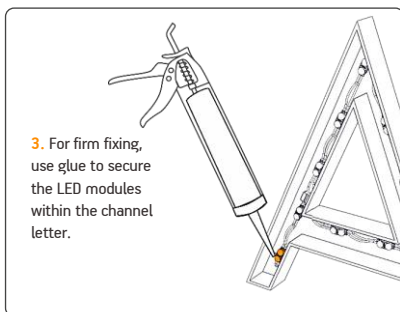
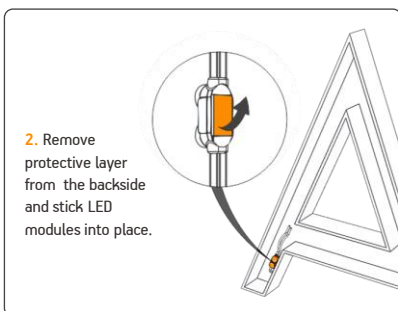
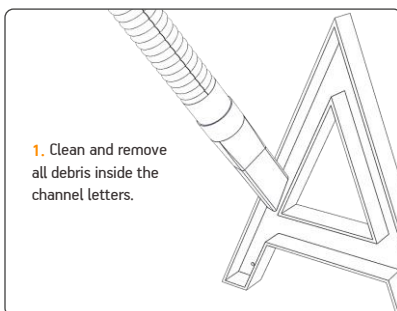
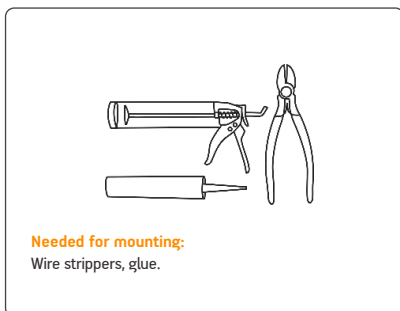

## CONNECTION SCHEME

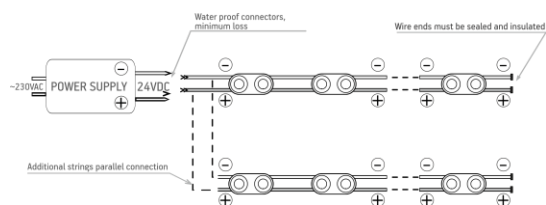
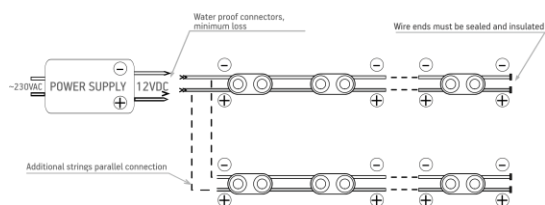

! 40 pcs - max number of modules in one chain when the power supplied from single end.  
! String end voltage can't be less than 10V, do not exceed specified module string length

! 80 pcs - max number of modules in one chain when the power supplied from single end.  
! String end voltage can't be less than 20V, do not exceed specified module string length

## POWER SUPPLY LOAD RECOMMENDATIONS

| 12 VDC<br>POWER SUPPLY | QUANTITY<br>modules | 2 m*            |     | 5 m*            |     | 10 m*           |     |
|------------------------|---------------------|-----------------|-----|-----------------|-----|-----------------|-----|
|                        |                     | mm <sup>2</sup> | AWG | mm <sup>2</sup> | AWG | mm <sup>2</sup> | AWG |
| BPSP-40-12V.1          | 160                 | 1.3             | 16  | 2.5             | 13  | 6               | 10  |
| BPSP-60-12V.1          | 240                 | 1.5             | 15  | 4               | 11  | 10              | 7   |
| BPSP-100-12V.1         | 400                 | 2               | 14  | 6               | 10  | 10              | 7   |
| BPSP-150-12V.1         | 600                 | 3.3             | 13  | 10              | 7   | 16              | 5   |

| 24 VDC<br>POWER SUPPLY | QUANTITY<br>modules | 2 m*            |     | 5 m*            |     | 10 m*           |     |
|------------------------|---------------------|-----------------|-----|-----------------|-----|-----------------|-----|
|                        |                     | mm <sup>2</sup> | AWG | mm <sup>2</sup> | AWG | mm <sup>2</sup> | AWG |
| BPSP-40-24V.1          | 160                 | 1.3             | 16  | 2.5             | 13  | 6               | 6   |
| BPSP-60-24V.1          | 240                 | 1.5             | 15  | 4               | 11  | 10              | 10  |
| BPSP-100-24V.1         | 400                 | 2               | 14  | 6               | 10  | 10              | 10  |
| BPSP-150-24V.1         | 600                 | 3.3             | 13  | 10              | 7   | 16              | 16  |

\* Distance between power supply and modules.  
! Recommendations for optimal use of power supply.

© 2024, All rights reserved BaltLED, UAB. Specifications are subject to change without notice.

5 YEARS WARRANTY

IP 65

CE

UK CA

RoHS Compliant

—

# MINI HE installation guide

## SAFETY PRECAUTIONS

- Installation of modules must be carried out by a qualified technician in accordance with relevant electrical equipment handling standards.
- Before installing, make sure that the fixing area can bear the total weight of the modules.
- Modules and power supplies have absolute maximum ratings. Comply with the specifications to avoid failure, damage and injury.
- Do not modify the module. This may lead to damage, injury and will void the warranty.
- Do not connect the modules to a power supply that is turned on! Injury and module failure may occur. If a power supply is turned on with no load (for example because of a bad connection), turn the power supply off and allow 5 minutes for it to fully discharge before continuing work on the installation.
- Avoid placing any high temperature objects around the modules. Also avoid putting cloth or paper on the modules. It may lead to combustion, burnout, overheat, failure, deformation.
- Before performing maintenance, turn off the power and allow the modules to cool down. Otherwise there is a danger of burns or electric shock.
- Do not wipe or spray modules with volatile materials such as thinner or benzene as it may lead to damage or spontaneous combustion.
- If there are any signs of smoke or there is a smell of burnt plastic, turn off power to the installation immediately and investigate the power supply and wiring carefully.
- Ensure that power supply and other system components are properly earthed if using Class 0 or Class I power supplies.

## INSTALLATION RECOMMENDATIONS

- The adhesive tape is for temporary mounting only! Additional adhesives or fasteners must be used for permanent installation.
- Be sure to install modules in maintainable places.
- Avoid using excessive force during installation in order to minimize the risk of damage to modules or cabling.
- Be careful not to go beyond the recommended maximum quantities of modules for a given power supply. Overload may cause blinking, uneven illumination or failure.
- These modules are designed to work with constant-voltage power supplies. Use only recommended power supplies. Do not connect to constant-current power supplies, as doing so will cause immediate failure of modules.
- Please install LED modules using appropriate cables. There is a possibility of cables disconnecting or breaking due to shrinkage caused by temperature changes.
- Make sure to provide sufficient ventilation and rainwater drainage for the installation containing the modules to prevent shortening their lifetime due to excess heat, long-term exposure to water or ice damage. Operating temperature should be within -30-50 °C.
- When fixing the cabling of the installation, avoid using metal cable ties or brackets – they may damage the cable insulation and cause short-circuits.
- In order to prevent LED breakdown caused by static discharge, make sure not to touch the wiring of the modules with bare hands.
- Make sure to check the module connections for the correct polarity. Reversed connections may lead to failure.
- Do not pull on the wiring while removing the modules – risk of damage.
- Do not install modules under direct sunlight or falling water – premature failure may occur.

## STORAGE AND GENERAL REMARKS

- Make sure to store modules in a dry place, avoid elevated temperatures, high pressures, vibrations, corrosive or combustible materials, direct sunlight.
- Modules cannot be used in combination with other types of modules. This may cause colour and brightness mismatches and lead to premature failure.
- Please ensure that the materials and components used in the installation do not contain or emit sulphuric compounds. Sulphuric compounds attack the LED module components and may lead to changes in colour and premature failure.
- Make sure to keep records of the lot numbers and installation dates of the modules.